

ER-2A Style

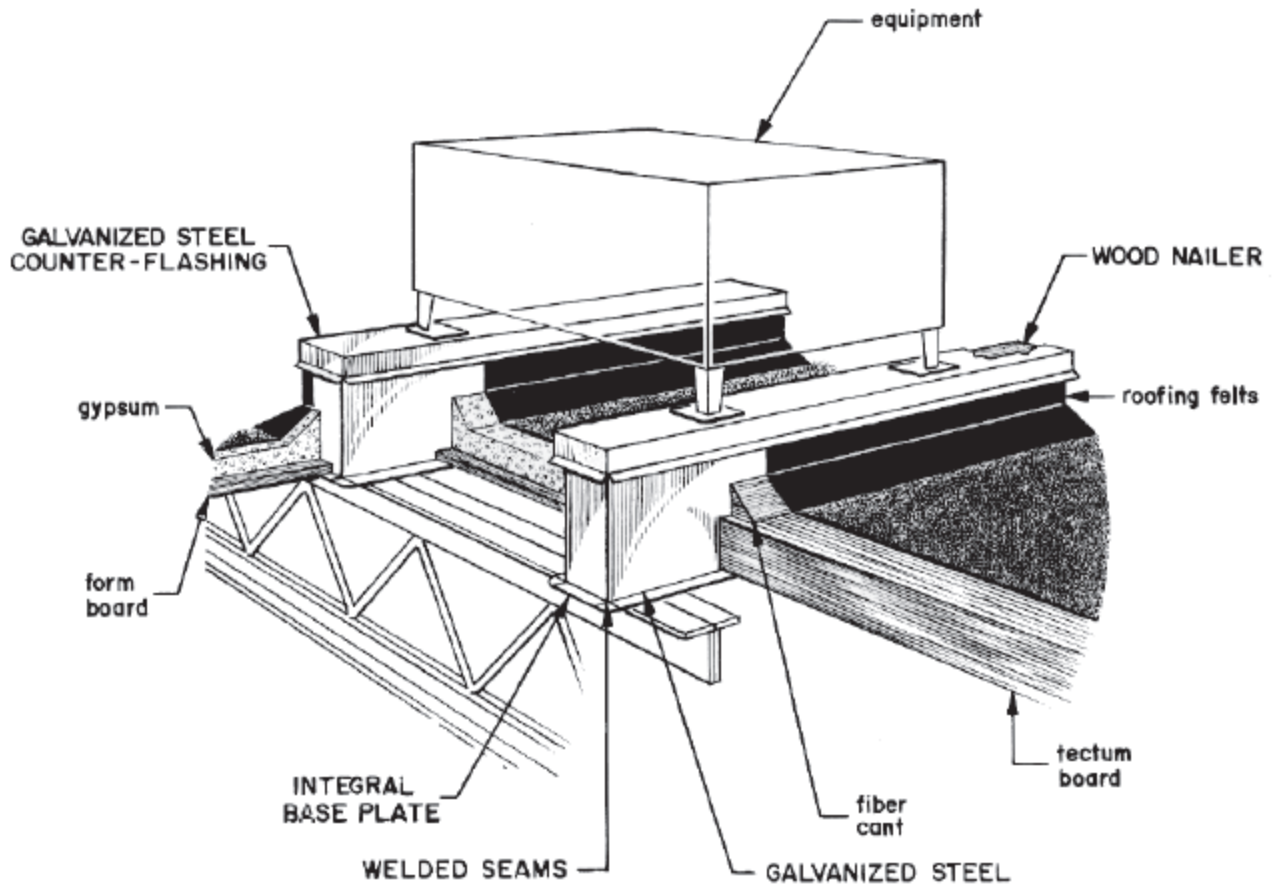

SPECIFICATION

Furnish and install equipment rails as manufactured by Portals Plus Inc.

The equipment rails shall be 18 gauge galvanized steel, monolithic construction, with integral base plate, continuous welded corner seams, factory installed 2 x 4 wood nailer, and including an 18 gauge galvanized counter-flashing complete with screws.

On Single-Ply Roofing, Lightweight Fill, or Tapered Insulation use style ER-2A. with a height of 12" overall.

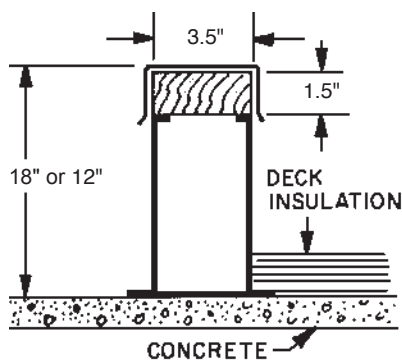

ER-2A STYLE