

Installation Instructions

READ COMPLETE INSTRUCTIONS CAREFULLY BEFORE STARTING

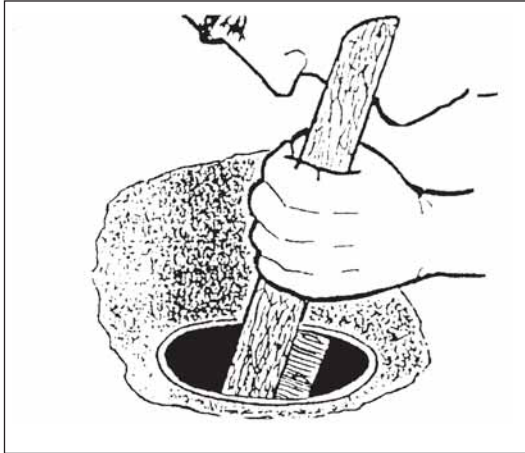

STEP 1

Inspect existing drain pipe to ensure there are no cracks or signs of potential failure. Using a wire brush, clean existing drain line to remove any asphalt, loose debris and other foreign material.

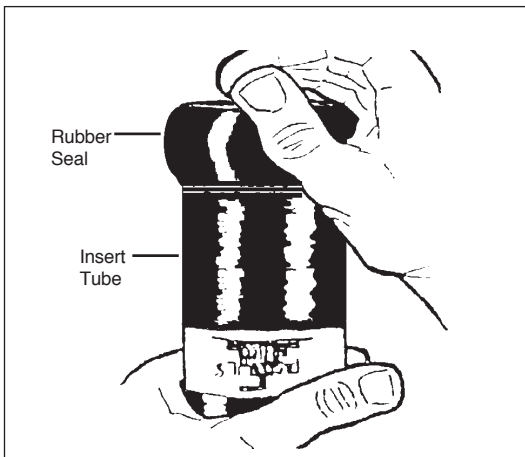

STEP 2

Ensure drain sleeve is the proper size before continuing. Be certain that the rubber seal is fully engaged onto the tube of the ReRoof Drain. To ease installation into the existing drain pipe, water may first be applied to the surface of the rubber seal. Insert the leading edge of the rubber seal into the existing drain pipe and simply rotate the ReRoof Drain in a clockwise motion while pushing the ReRoof Drain down to seat the flange into the membrane manufacturer's recommended adhesive. The flat flange allows a flush mount. Secure the ReRoof Drain to the deck by installing insulation fasteners through the prepunched flange holes.

NOTE: The ReRoof Drain insert tube can be shortened in the field by cutting the tube after removing the rubber seal. Cut the end of the tube square and remove any burrs or rough edges. Replace the rubber seal onto the end of the tube. The rubber seal forms a tight gasket between the tube and the existing drain pipe in the event of a water backup.

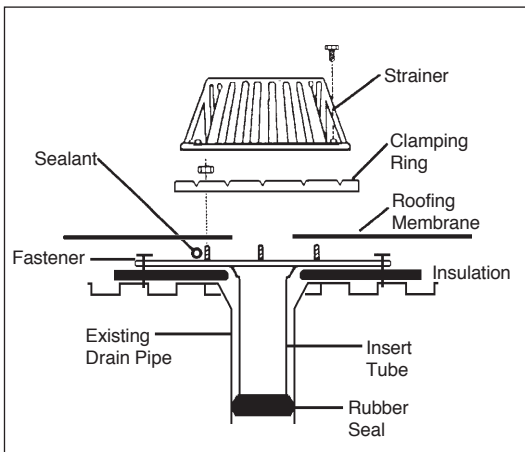

STEP 3

Prior to installing dome strainer and clamping ring, per Roofing Manufacturers recommendations, apply sealant on the drain flange. Bring roof membrane onto drain flange. Membrane should extend past drain clamping ring to insure membrane from slipping out. Install clamping ring and tighten so the sealant and membrane compress and form a watertight gasket. Do not tighten bolt greater than 100 torque inch pounds.

With all good roofing practice, all drains should be water tested to ensure existing drain system is free to facilitate water flow. Extended insert tubes are available for excessive insulation buildup.