

### Straight Flange Installation Instructions

#### READ COMPLETE INSTRUCTIONS CAREFULLY BEFORE STARTING

##### ROOF EDGE PREPARATION

On both sides of expansion joint opening, install wood nailers and tapered edge strips. Taper wood nailers and tapered edge strips down to feathered edge at eave. Install roofing as specified by roofing membrane manufacturer to edge of expansion joint opening and edge of roof.

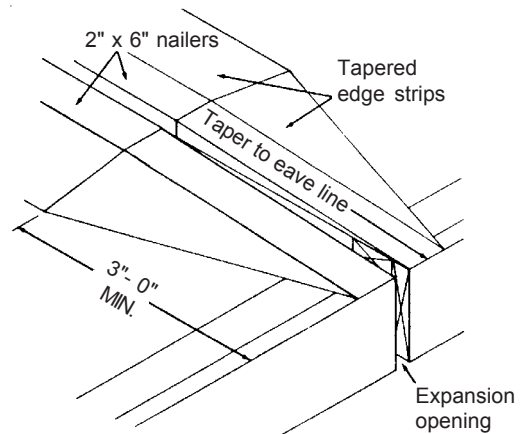

##### METAL EDGE TERMINATIONS

Before bending metal at edge, slit foam insulation and remove as shown

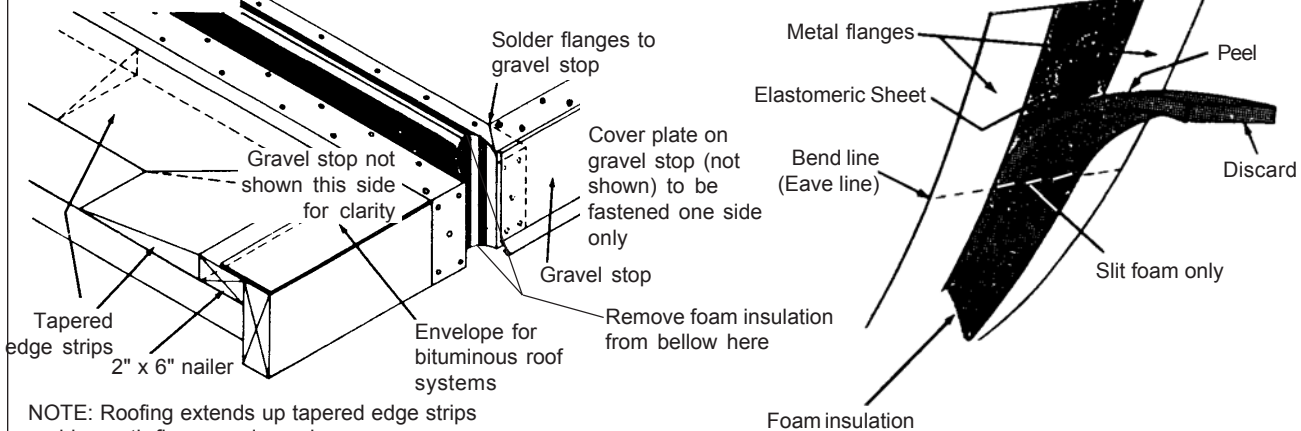

NOTE: Roofing extends up tapered edge strips and beneath flange and envelope

##### GUTTER TERMINATIONS

Expansion joint for gutter is made in the shop by removing foam from expansion joint cover and forming metal flanges to fit gutter. Solder and rivet flanges to gutter each side. Leave buckle in elastomeric sheet for gutter movement.

