



# Pipe Portal Systems

Technical Product Information

## Pipe Portal with C-481 Cap

### SPECIFICATION

Furnish and install the Portals Plus Pipe Portal System as manufactured by Portals Plus, Inc., Bensenville, IL, at all points where up to four pipes .375" - 1" in diameter penetrate the roof. The Pipe Portal shall include an 18 gauge galvanized roof curb model RC-\_\_\_A with integral base plate, continuously welded corner seams, factory-installed wood nailer, and 1.5" 3lb. rigid fiberglass insulation. The Pipe Portal shall be furnished with a laminated, acrylic coated, ABS plastic curb cover with prepunched holes and molded sealing ring on an 8" collared opening. An EPDM (Ethylene Propylene Diene Monomer) compression molded cap model C-481 shall be utilized. All Caps shall include Portals Plus' stainless steel Snaplock Clamps. Attachment and installation of the Pipe Portal shall be done in accordance with Portals Plus' instructions and the roofing membrane manufacturer's recommendations.

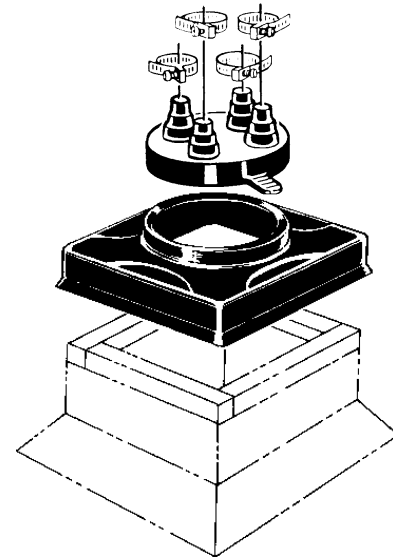

NOTE: All dimensions are I.D. of conical shaped nipples

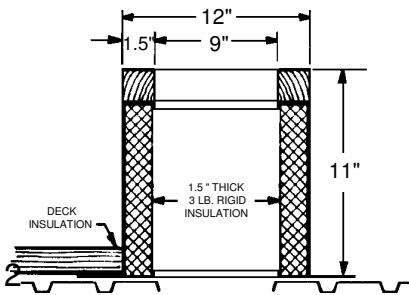
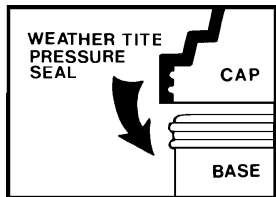
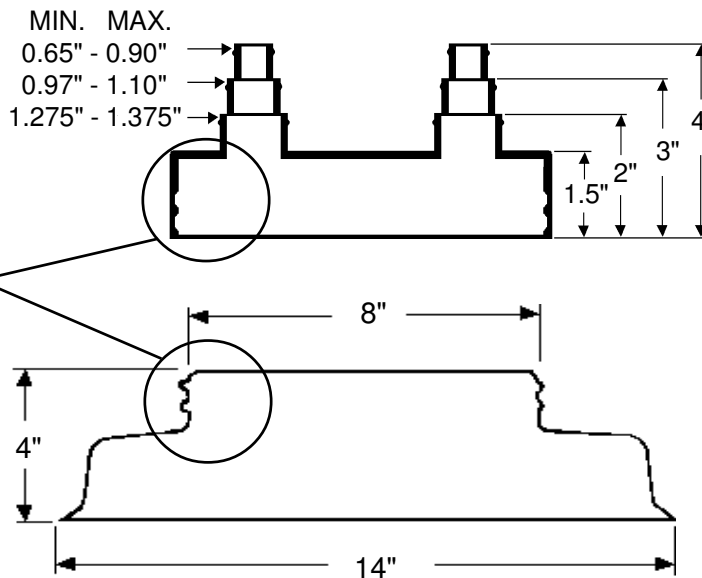

### RC-2A

For Decks with Lightweight Fill or Tapered Insulation

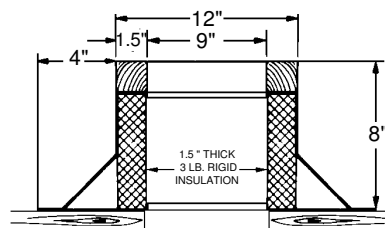

### RC-3A

For Noninsulated Decks

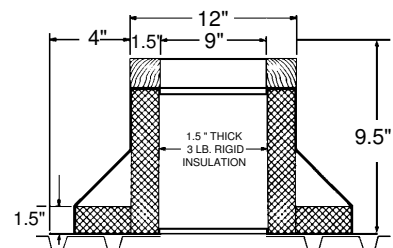

### RC-4A

For Decks with Rigid Insulation